

RPC-N
50 Ω

Airline Plug/Jack

05S101-K100

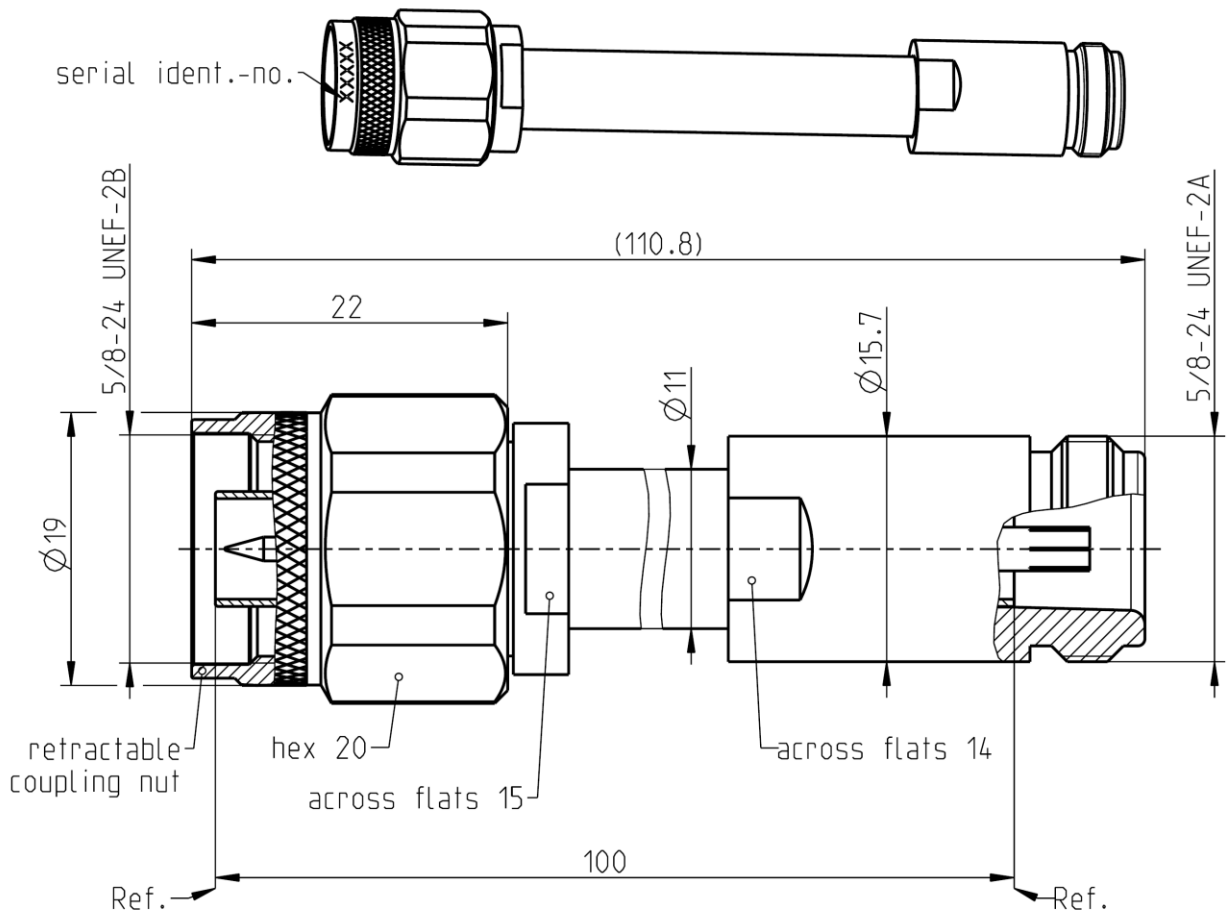

All dimensions are in mm; tolerances according to ISO 2768 m-H

Interface

According to

IEC 60169-16 ; CECC 22 210 ; MIL-STD 348A/402

Documents

N/A

Material and plating

Connector parts

Center conductor
Outer conductor
Coupling nut

Material

CuBe
Brass
Stainless steel

Plating

Gold, min. 1.27 μm, over chemical nickel
Gold, min. 1.27 μm, over chemical nickel
Passivated

RPC-N
50 Ω

Airline Plug/Jack

05S101-K100

Electrical data

Insertion loss ≤ 0.25 dB, 0.3 GHz to 18 GHz

Mechanical data

Mating cycles ≥ 500
 Maximum torque 1.70 Nm
 Recommended torque 1.10 Nm
 Airline dimensions at 23 °C:
 - Diameter outer conductor 7.000 mm ± 0.005 mm
 - Diameter inner conductor 3.040 mm ± 0.005 mm
 - Length outer conductor 100.00 mm + 0.02 mm
 - Length inner conductor 100.00 mm - 0.02 mm
 - Length difference ≤ 0.04 mm
 (outer conductor – inner conductor)

Calculated data (non warranted)

Lossless characteristic impedance¹ 50 Ω ± 0.35 Ω
 Return loss² ≥ 40 dB, 0.3 GHz to 4 GHz
 ≥ 35 dB, 4 GHz to 18 GHz

1. The lossless characteristic impedance is calculated from the specified diameters of the inner and outer conductor.
2. The return loss is calculated from the characteristic impedance, the skin depth and the connector interface.

General standard definitions

For proper work the vector network analyzer (VNA) used needs a model describing the electrical behaviour of this calibration standard. Depending on the VNA type different models, units and terms are used and have to be entered into the VNA. All values are based on typical geometry and plating.

- Offset Z_o / Impedance / Z_o 50 Ω
 - Offset Delay 333.706 ps
 - Length (electrical) / Offset Length 100.042 mm
 - Offset Loss 1.70 GΩ/s
 - Loss 0.0493 dB/√GHz

Environmental data

Operating temperature range³ +20 °C to +26 °C
 Storage temperature range 0 °C to +50 °C
 RoHS compliant

3. This range is a recommendation. However, the airline can be used in a wider range. Any temperature change from 23 °C results in dimensional changes.

Packing

Standard 1 pce in box
 Weight 102.5 g/pce
 Center conductor loose in an acrylic glass tube

While the information has been carefully compiled to the best of our knowledge, nothing is intended as representation or warranty on our part and no statement herein shall be construed as recommendation to infringe existing patents. In the effort to improve our products, we reserve the right to make changes judged to be necessary.

Draft	Date	Approved	Date	Rev.	Engineering change number	Name	Date
Herbert Babinger	03.08.04	Martin Moder	27.09.23	g00	23-1604	Matthias Gehl	27.09.23
Rosenberger Hochfrequenztechnik GmbH & Co. KG P.O.Box 1260 D-84526 Tittmoning Germany www.rosenberger.de				Tel. : +49 8684 18-0 Fax : +49 8684 18-499 Email : info@rosenberger.de			Page 2 / 2